

DESCRIPTION

Solenoid valve 2 way normally open
direct acting poppet type

CONSTRUCTION

Body	Brass
Armature tube	Brass
Plunger and core	AISI 430FR
Springs	AISI 302
Seal material	NBR - FPM - EPDM



2

FEATURES

Maximum allowable pressure PS 50bar^⑤
 Maximum fluid viscosity 25cSt (mm²/s)
 Ambient temperature: from -10°C to +80°C according to the coil
 Universal mounting position

OPTIONS: Stainless steel armature tube
 Electroless nickel plating
 c us certified coils

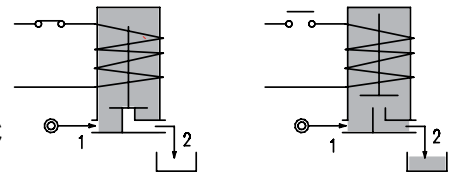
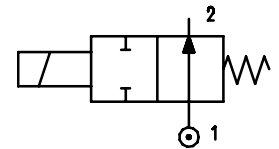

ON REQUEST: Versions for use with fluid temperature at -40°C
 Manual override

CODE ① ② ③	Connection G ISO 228	Orifice mm	Kv m ³ /h	Pressure range bar			Nominal power			Coil		Seal ②	Temp. range °C	
				Min	Max		AC Inrush	VA Holding	DC Watt	Series	Width			
					AC	DC								
E206... ..15///...	1/8"	1.5	0.07	0	23	20	15	-	2	30	NBR=B EPDM=E FPM=V	-10 +90 -10 +140 -10 +140		
E206... ..20///...		2	0.1	0	17									
E206... ..25///...		2.5	0.15	0	12									
E206... ..30///...		3	0.25	0	9									
E206... ..35///...		1/4"	3.5	0.32	0								7	
E206... ..40///...			4	0.36	0								5.5	
E206... ..45///...			4.5	0.41	0								4.5	
E206... ..52///...			5.2	0.47	0								3	
D206... ..15/3/...	1/8"	1.5	0.07	0	-	-	-	10	2	30				
D206... ..20/3/...		2	0.1	0	-								18	
D206... ..25/3/...		2.5	0.15	0	-								11	
D206... ..30/3/...		3	0.25	0	-								7	
D206... ..35/3/...		1/4"	3.5	0.32	0								-	6.5
D206... ..40/3/...			4	0.36	0								-	4
D206... ..45/3/...			4.5	0.41	0								-	3
D206... ..52/3/...			5.2	0.47	0								-	2.2
E206... ..15///...	1/8"	1.5	0.07	0	23	40	30	27	5	36				
E206... ..20///...		2	0.1	0	17									
E206... ..25///...		2.5	0.15	0	12									
E206... ..30///...		3	0.25	0	9									
E206... ..35///...		1/4"	3.5	0.32	0						7			
E206... ..40///...			4	0.36	0						5.5			
E206... ..45///...			4.5	0.41	0						4.5			
E206... ..52///...			5.2	0.47	0						3			
E206... ..64///...		6.4	0.64	0	3.5									

- ① Connection: A=1/8" , B=1/4"
- ② Seal Example: E206BB35///20E 1/4"connections, NBR seals
- ③ Coil Coil 230V 50/60Hz
- ④ The maximum allowable pressure PS for steam is 2.5bar (gauge pressure)

COILS ③	Alternating Current 50/60Hz (V)							Direct Current (V)			Electrical connection	Connectors
	12	24	48	110	220 230	240	380	12	24	48		
Series 2 Width 30	20A	20B	20C	20D	20E	20F	20G	200	201	202	DIN 43650A	PG9 code 10349000
Series 5 Width 36	52A	52B	52C	52D	52E	52F	52G	520	521	522	DIN 43650A	PG11 code 10349001

DESCRIPTION
 Insulation class
 Series 2 =F Series 5=H
 Voltage tolerance
 AC +15% -10%
 DC ± 10%
 Protection class
 IP65 with connector fitted
 IP00 without connector

OPTIONS
 Class H insulation (series 2)
 Cable attached
 Special coil voltage
 Special coil powers
 c US certified coils

(for coil details see section 8)

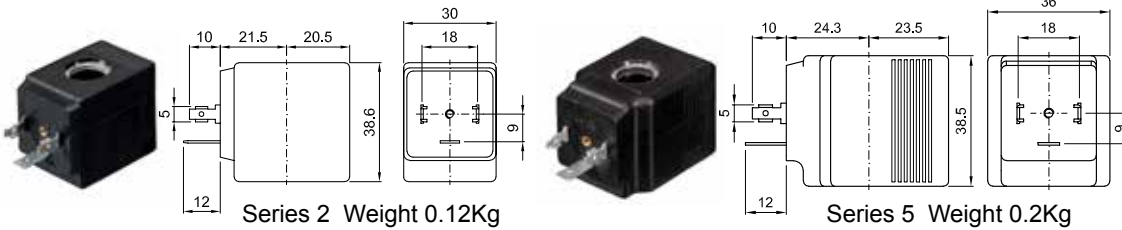

Series 2 Weight 0.12Kg

Series 5 Weight 0.2Kg

SPARE PARTS LIST

1. Coil fixing nut
2. Coil
3. Seal assembly
4. Armature tube assembly

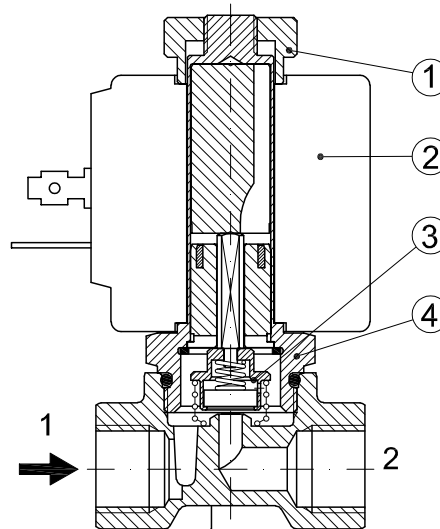

OVERALL DIMENSION

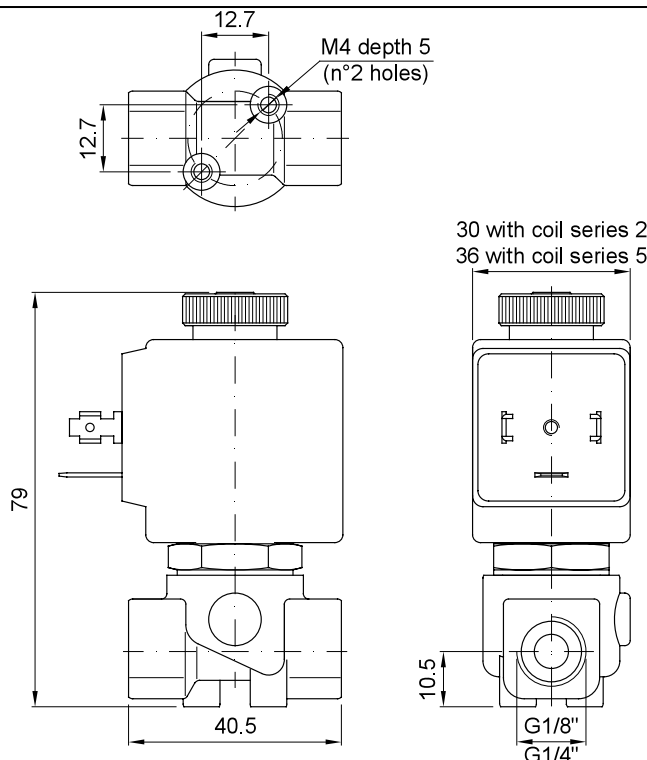

Weight with coil series 2=0.30Kg
 Weight with coil series 5=0.38Kg

DESCRIPTION

Solenoid valve 2 way normally open
direct acting poppet type

CONSTRUCTION

Body	Brass
Armature tube	Brass
Plunger and core	AISI 430FR
Springs	AISI 302
Seal material	NBR - FPM - EPDM



2

FEATURES

- Maximum allowable pressure PS 50bar^③
- Maximum fluid viscosity 25cSt (mm²/s)
- Ambient temperature: from -10°C to +80°C according to the coil
- Universal mounting position

- OPTIONS:** Stainless steel armature tube
Electroless nickel plating
c US certified coils

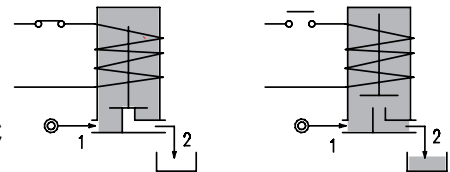
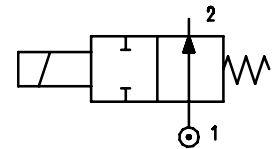

ON REQUEST: Versions for use with fluid temperature at -40°C
Manual override

CODE ① ② ③	Connection G ISO 228	Orifice mm	Kv m ³ /h	Pressure range bar			Nominal power			Coil		Seal ②	Temp. range °C							
				Min	Max		AC Inrush	VA Holding	DC Watt	Series	Width									
					AC	DC														
E206... ..15///...	3/8"	1.5	0.07	0	23	20	15	-	2	30	NBR=B	-10 +90								
E206... ..20///...		2	0.1	0	17															
E206... ..25///...		2.5	0.15	0	12															
E206... ..30///...		3	0.25	0	9															
E206... ..35///...		1/2"	3.5	0.32	0								7	-	-	10	2	30	EPDM=E	-10 +140
E206... ..40///...			4	0.36	0								5.5							
E206... ..45///...			4.5	0.41	0								4.5							
E206... ..52///...			5.2	0.47	0								3							
D206... ..15///...	3/8"	1.5	0.07	0	-	-	-	-	2	30	FPM=V	-10 +140								
D206... ..20///...		2	0.1	0	-															
D206... ..25///...		2.5	0.15	0	-															
D206... ..30/3/...		3	0.25	0	-															
D206... ..35/3/...		1/2"	3.5	0.32	0								-	40	30	27	5	36		
D206... ..40/3/...			4	0.36	0								-							
D206... ..45/3/...			4.5	0.41	0								-							
D206... ..52/3/...			5.2	0.47	0								-							
E206... ..15///...	3/8"	1.5	0.07	0	23	40	30	27	5	36										
E206... ..20///...		2	0.1	0	17															
E206... ..25///...		2.5	0.15	0	12															
E206... ..30///...		3	0.25	0	9															
E206... ..35///...		1/2"	3.5	0.32	0								7							
E206... ..40///...			4	0.36	0								5.5							
E206... ..45///...			4.5	0.41	0								4.5							
E206... ..52///...			5.2	0.47	0								3							
E206... ..64///...		6.4	0.64	0	3.5															

① Connection: C=3/8", D=1/2"

② Seal

③ Coil

④ The maximum allowable pressure PS for steam is 2.5bar (gauge pressure)

Example: E206CB45///20B 3/8" connection, NBR seal
Coil 24V 50/60Hz

COILS ③	Alternating Current 50/60Hz (V)							Direct Current (V)			Electrical connection	Connectors
	12	24	48	110	220 230	240	380	12	24	48		
Series 2 Width 30	20A	20B	20C	20D	20E	20F	20G	200	201	202	DIN 43650A	PG9 code 10349000
Series 5 Width 36	52A	52B	52C	52D	52E	52F	52G	520	521	522	DIN 43650A	PG11 code 10349001

DESCRIPTION
 Insulation class
 Series 2 =F Series 5=H
 Voltage tolerance
 AC +15% -10%
 DC ± 10%
 Protection class
 IP65 with connector fitted
 IP00 without connector

OPTIONS
 Class H insulation (series 2)
 Cable attached
 Special coil voltage
 Special coil powers
 us certified coils

(for coil details see section 8)

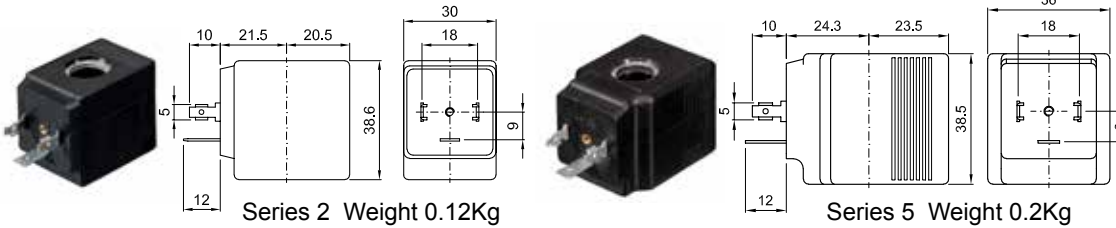

SPARE PARTS LIST

1. Coil fixing nut
2. Coil
3. Seal assembly
4. Armature tube assembly

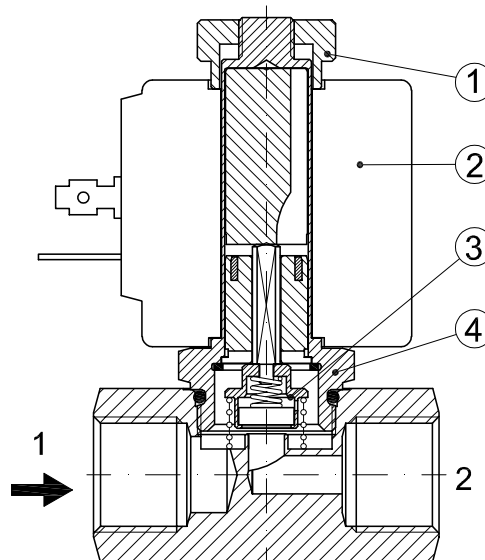

OVERALL DIMENSION

