

MACP403 series

AIR UNIT (F.R.L.UNIT)



Option: **MP41**

Symbol

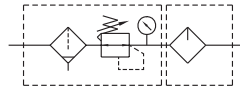

Specification

Model	MACP403		
Components	MAFR403, MAL403		
Bore No.	8A	10A	15A
Port size	1/4	3/8	1/2
Medium	Air		
Operating pressure range (*)	0.05~1 MPa		
Proof pressure	1.5 MPa		
Regulated pressure range	0.1~0.85 MPa		
Ambient temperature	- 5~+60°C (No freezing)		
Filter element	Standard: 40µm, Option: 5µm		
Lubricating oil capacity	200c.c		
Min. flow for oil drip	30 l/min	65 l/min	80 l/min
Recommended lubricating oil	Turbine oil ISO-VG32		
Attachment	Pressure gauge (PG-20), L-type bracket		
Weight	1100 g		

* Standard unit contains semi-auto-drain function when operating pressure below 0.05 MPa.

* Choose auto-drain FMRF300, the pressure range is 0.15~1 MPa.

Order example

MACP403 – 8A – NC□P□ – E1 – □ – T8 – HR – □

MODEL

PORT SIZE

8A: 1/4
10A: 3/8
15A: 1/2

(Option)

PRESSURE SWITCH

E1: MP41P-022
E2: MP41P-022-QD
E5: MP41P-042
E6: MP41P-042-QD

* Refer to page 5-13 for MP41.

FILTER ELEMENT

Blank: 40µm
5u: 5µm

(Option)

BY-PASS PORT SIZE

T type bracket	T8: 1/4 T10: 3/8 T15: 1/2
Check valve	K8: 1/4 K10: 3/8

PORT THREAD

Blank: Rc thread
G: G thread
NPT: NPT thread

(Option)

SHUTOFF VALVE

HR: MVHR-400-3H
1: MVHR-400S-3H-AC110
1L: MVHR-400S-3H-AC110-L
2: MVHR-400S-3H-AC220
2L: MVHR-400S-3H-AC220-L
4: MVHR-400S-3H-DC24
4L: MVHR-400S-3H-DC24-L
4E: MVHR-400S-3H-DC24-E

* 400: Manual type,
400S: Solenoid type.
* Refer to page 3-71 for MVHR.

(Option)

Bowl	Pressure gauge	Drain valve	Pressure switch	Flow direction
Blank: PC bowl N: Nylon bowl	Blank: Pressure gauge (PG-20) C: External pressure gauge (PG-40) + Gauge adapter set (A-MAR302) A: Gauge adapter set (A-MAR302)	Blank: Semi-auto drain D: Auto drain valve (FMRF300)	P: Pressure switch (MPS series)	Blank: L: Left to right R: Right to left

* PG-40 (C), A-MAR302 (A) and MP41 (E*) can not be selected at the same time.

* Be sure to use above check valves when redirecting the air flow on the inlet side of the lubricator.

Flow feature

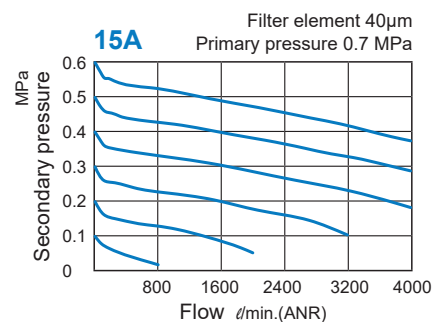
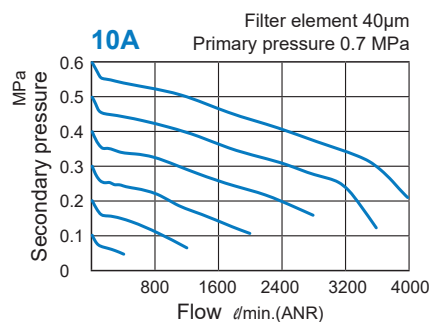
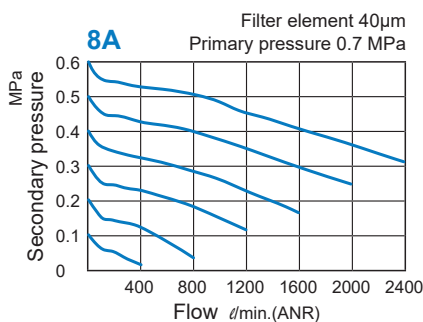

MACP403 Dimensions

AIR UNIT (F.R.L.UNIT)



Accessories

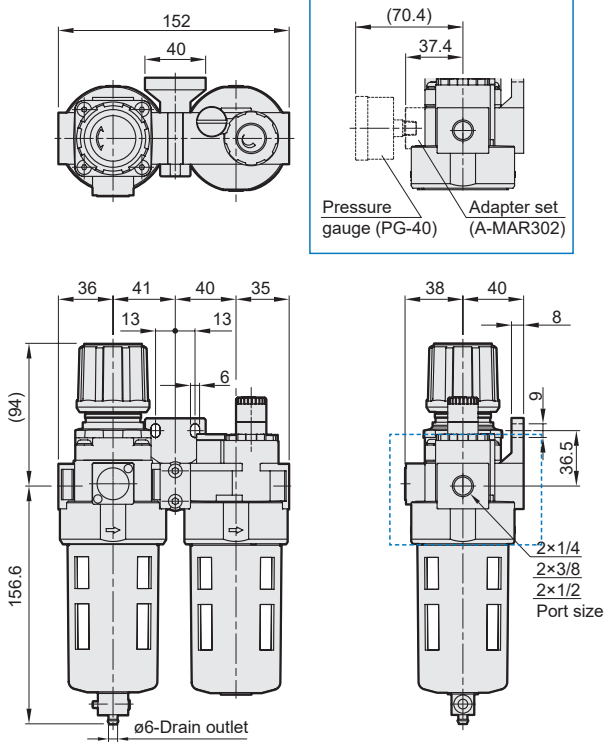

MACP403-D

Auto drain valve

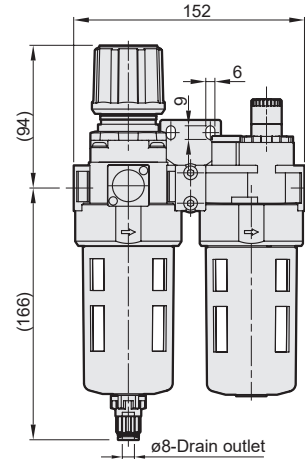

MACP403-T*

T type bracket

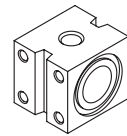
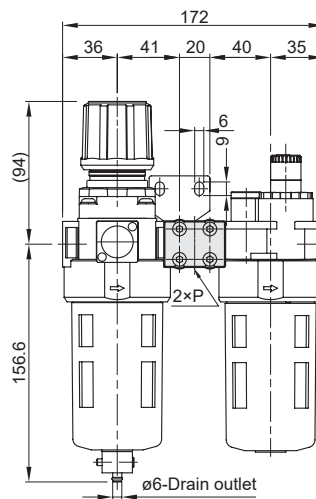

Port Bracket	P
T8	1/4
T10	3/8
T15	1/2

MACP403-K*

Check valve

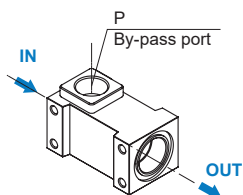
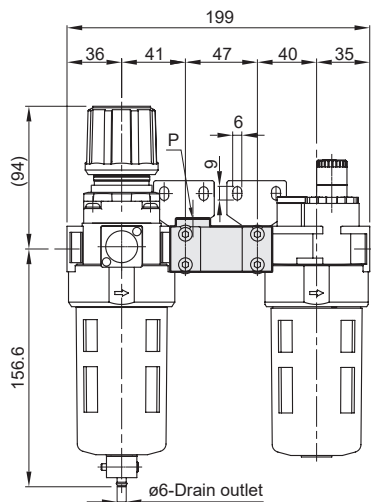

Port Check valve	P
K8	1/4
K10	3/8

MACP403-P

MPS Series pneumatic pressure switch

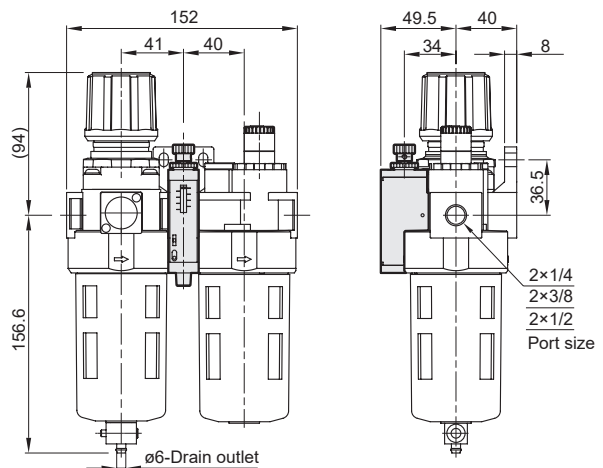

* Threads for IN and OUT ports are not machined.

MACP403-HR With shutoff valve

AIR UNIT (F.R.L.UNIT)



MACP403-HR

With shutoff valve (MVHR-400)

MACP403-1*1/2*/4*

With shutoff valve (MVHR-400S)

Accessories

