

MAL401 series

AIR UNIT (L.UNIT)



Option: **MLF400**

Symbol

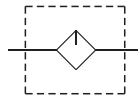

Specification

Model	MAL401		
Bore No.	8A	10A	15A
Port size	1/4	3/8	1/2
Medium	Air		
Max. operating pressure	1.5 MPa		
Proof pressure	2 MPa		
Ambient temperature	- 5~+60°C (No freezing)		
Lubricating oil capacity	200 c.c		
Max. flow rate (*) ℓ/min	1200	2000	2100
Min. Flow for oil drip	30 ℓ/min	65 ℓ/min	80 ℓ/min
Recommended lubricating oil	Turbine oil ISO-VG32		
Weight	545 g		

* Flow is at pressure P=0.7 MPa with pressure drop ΔP=0.03 MPa. (ANR)

Order example

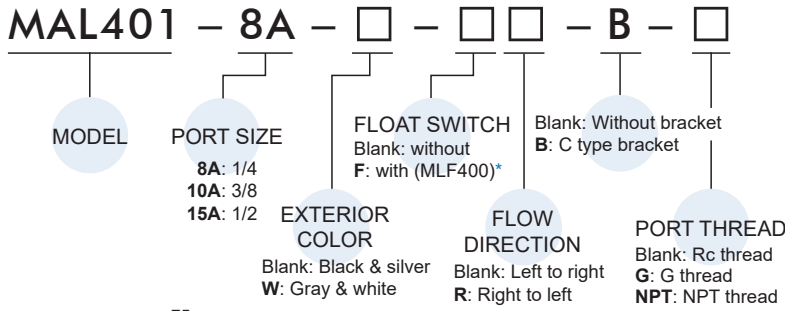

Option accessories

C type bracket

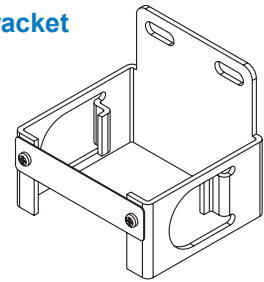

* The specification please refer to page 4-**.

