

K 160/200

Pneumatic cylinders ISO 15552

- High payload series
- With aluminium tube and tie-rods
- High temperature seals available on request

Available ATEX version upon request

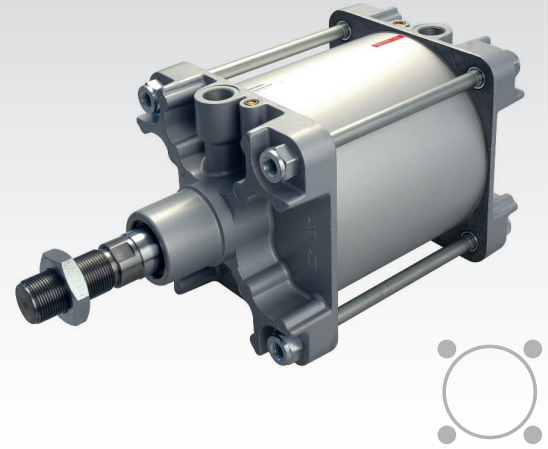

TECHNICAL CHARACTERISTICS

Working temperature	-20 ÷ 80 °C
Fluid	filtered air, with or without lubrication
Working pressure	1,5 ÷ 10 bar
Bore size	Ø160 - 200 mm
Cushioning	adjustable in both sides

CONSTRUCTIVE CHARACTERISTICS

End caps	die-cast aluminium alloy (painted)
Barrel	anodized aluminium
Tie rods	zinc-plated steel
Piston	die-cast aluminium alloy
Piston rod guide	acetal resin
Piston rod	C43 chromium-plated steel (standard) stainless steel, rolled AISI 303
Piston rod scraper seals	nitrile rubber (NBR)
Piston seal	polyurethane PU (Ø160) - nitrile rubber NBR (Ø200)
Magnet	plasto-ferrite

Version available upon request



Ø160/200 Cylinder with profiled tube

CODIFICATION KEY

K	2	0	0	1	6	0	0	0	8	0		
1	2	3	4		5			6	7			

1 Series	2 Type	3 Version	4 Bore (mm)
K = Ø 160/200 mm - ISO 15552 Pneumatic Cylinders	1 = Stainless steel piston rod 2 = Chromium-plated steel piston rod	00 = D.A. Standard version 01 = D.A. Through piston rod D.A. = Double acting	160 = Ø160 200 = Ø200

5 Stroke (mm)	6 Magnetic	7 Atex option
0025 = 25 0150 = 150 0320 = 320 0700 = 700	M = Magnetic version	X = Atex (upon request) See ATEX Catalogue for types and versions
0050 = 50 0160 = 160 0350 = 350 0800 = 800		
0075 = 75 0175 = 175 0400 = 400 0900 = 900		
0080 = 80 0200 = 200 0450 = 450 1000 = 1000		
0100 = 100 0250 = 250 0500 = 500		
0125 = 125 0300 = 300 0600 = 600		

K190 and K290 versions with high temperature seals (Max 120°C) available upon request

Stroke tolerances

Ø	stroke ≤ 500	501 ≤ stroke ≤ 1000
	mm	mm
160	+4 - 0	+5 - 0
200	+4 - 0	+5 - 0

Theoretical forces (N) at different working pressure (bar)

Ø	Surface area		Working pressure					Working pressure				
	mm ²		bar					bar				
	Thrust	Traction	Thrust					Traction				
			2	4	6	8	10	2	4	6	8	10
160	20096	18850	4019	8038	12058	16077	20096	3770	7540	11310	15080	18850
200	31400	30144	6280	12560	18840	25120	31400	6029	12058	18066	24115	30144

Cushion

Length	Max kinetic energy absorption
mm	Nm
45	52
45	95

Mass - Standard cylinder

Ø	Cylinder - stroke 0	Increase per mm stroke	Moving element - stroke 0	Increase per mm stroke
	g	g	g	g
160	14600	16,9	4020	9,9
200	16500	18,5	4780	9,9

Mass - Through piston rod cylinder

Ø	Cylinder - stroke 0	Increase per mm stroke	Moving element - stroke 0	Increase per mm stroke
	g	g	g	g
160	16850	26,80	5940	19,8
200	19900	28,40	6800	19,8

Graph of theoretical forces/pressure and of acceptable strokes depending on maximum peak load

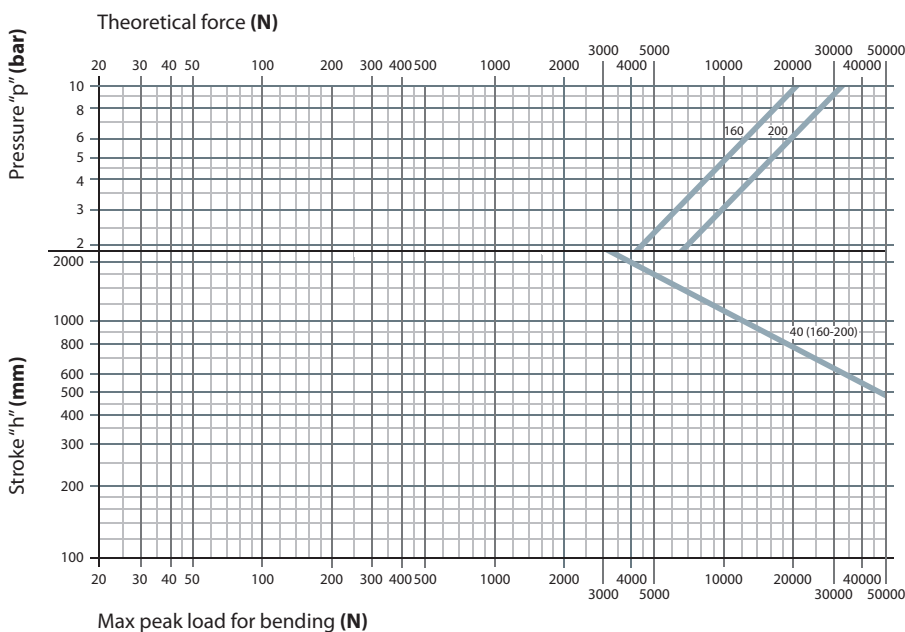

Fixing elements and accessories

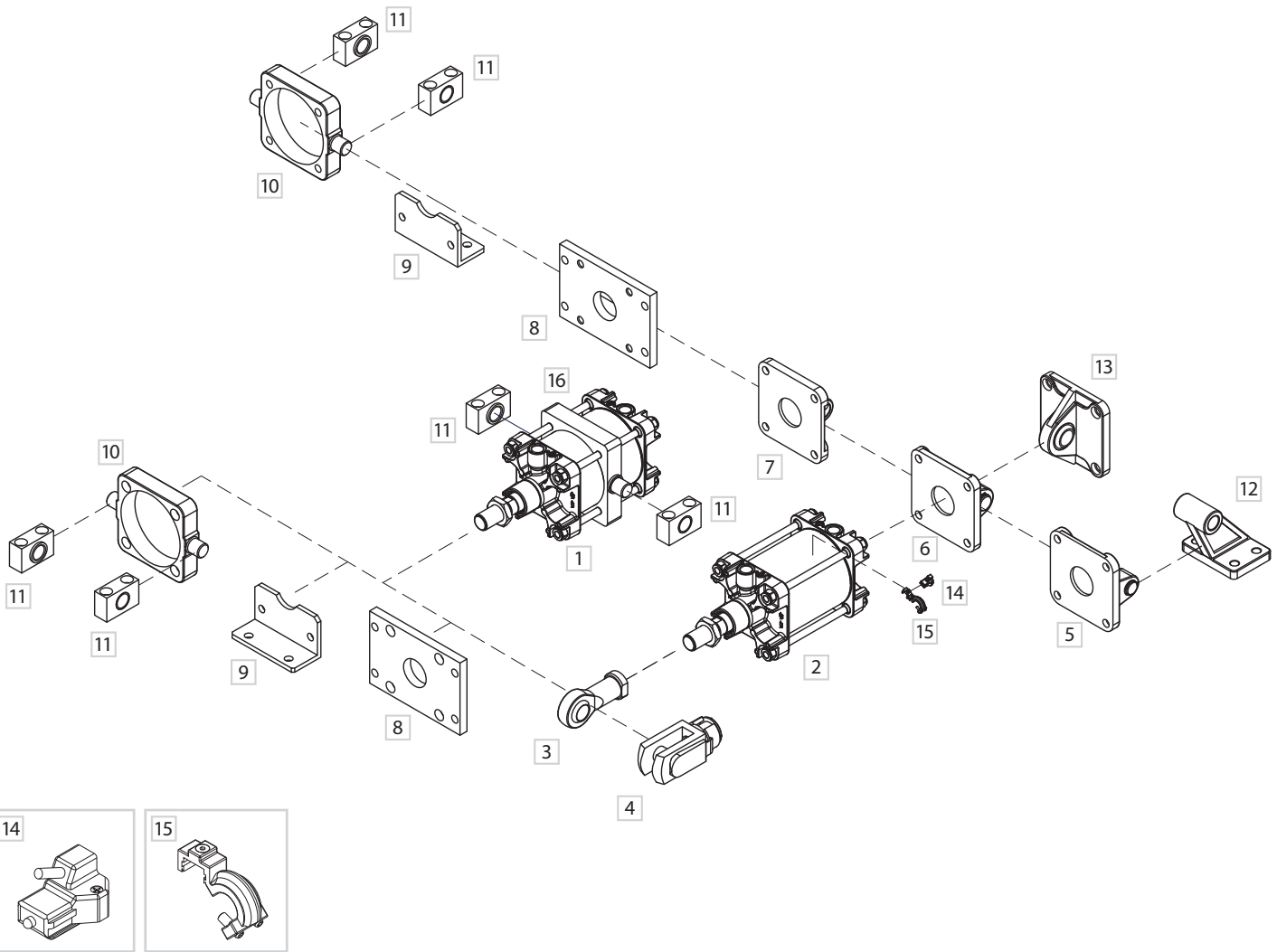

1
CYLINDERS

DESCRIPTION	PART NO.
1 ISO cylinder with intermediate hinge	-
2 ISO cylinder	-
3 Articulated self-lubricating fork	KF-17__
4 Female fork with clips	KF-15__
5 Female hinge (ISO MP2) with pin	KF-10__ A
6 Narrow female hinge with pin (DIN648K)	KF-10__ AS
7 Male rear hinge (ISO MP4)	KF-11__
8 Front- rear flange (ISO MF1-MF2)	KF-12__
9 Angle bracket (ISO MS1)	KF-13__
10 Front-rear hinge with floating pin	KF-14__ AP
11 Support for front-rear-intermediate hinge	KF-41__
12 Counter hinge 90° (CETOP RP107P)	KF-19__ CTA
13 Articulated rear male hinge (ISO MP6)	KF-11__ S
14 ISO intermediate hinge (ISO MT4)	DH-__
15 DH sensor	DH-__
16 Mounting bracket for DH sensor	KF-14__

Double acting standard version

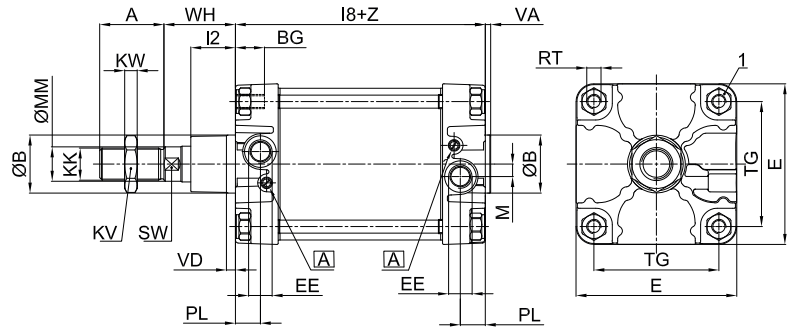
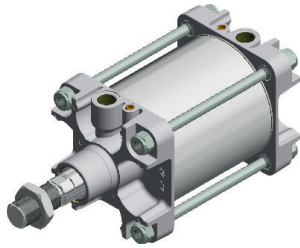

A Pneumatic cushioning adjusting screw

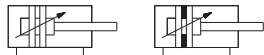

K100/200
D.A. Standard version

Double acting through piston rod

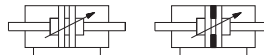
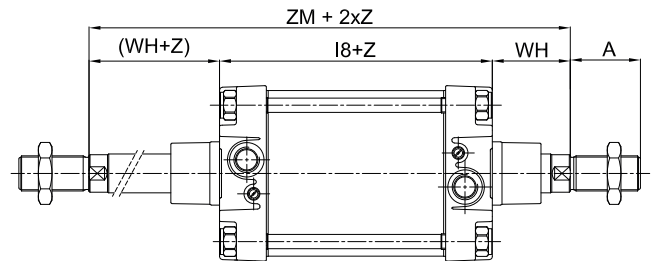
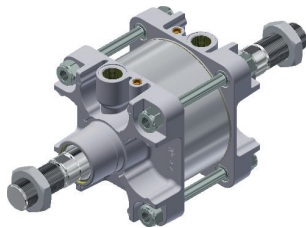

K101/201
D.A. Through piston rod

Z = Stroke

Ø	A ^(a)	B	BG	E	EE ^(b)	KK ^(a)	KV	KW	I2	I8	M	MM	PL	RT	SW	TG	VA	VD	WH	ZM	1			
160	72	65	25	180	G3/4	M36x2	55	14	50	180	±1,1	14	40	28	M16	36	140	±1,1	6	9	80	±2,2	340	27
200	72	75	25	220	G3/4	M36x2	55	14	60	180	±1,1	14	40	27	M16	36	175	±1,1	6	9	95	±2,2	370	27

(a) = A and KK dimension according to ISO 4395

(b) = EE according to ISO 228/1

Tandem version

CODIFICATION KEY

K	2	A	1	6	0	0	5	0	M
1	2	3			4		5		

1 Series	2 Type	3 Bore (mm)	4 Stroke (mm)	5 Magnetic
K = Ø 160/200 mm - ISO 15552 Pneumatic Cylinders	1A = Double thrust tandem only for forward movement, stainless steel piston rod 2A = Double thrust tandem only for forward movement, chromium-plated steel piston rod 1D = Double thrust tandem only for reverse movement, stainless steel piston rod 2D = Double thrust tandem only for reverse movement, chromium-plated steel piston rod	160 = Ø160 200 = Ø200	Upon request	M = Magnetic version

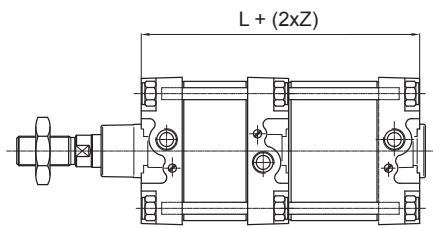

Z = Stroke	
Ø	L
160	340
200	350

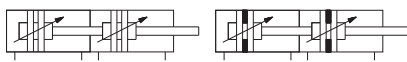

Tandem cylinders are constructed using two pistons coupled together which double the force in forward movement compared to the traditional ISO cylinders of the same bore size.

Two-position tandem version

CODIFICATION KEY

K	2	B	1	6	0	0	5	0	0	7	0	M
1	2	3			4		5			6		

1 Series	2 Type	3 Bore (mm)	4 Stroke Z1 (mm)	5 Stroke Z2 (mm)	6 Magnetic
K = Ø 160/200 mm - ISO 15552 Pneumatic Cylinders	1B = Two-position tandem, stainless steel male piston rod 2B = Two-position tandem, chromium-plated steel male piston rod	160 = Ø160 200 = Ø200	Stroke of rear cylinder (upon request)	Stroke of head cylinder (upon request)	M = Magnetic version

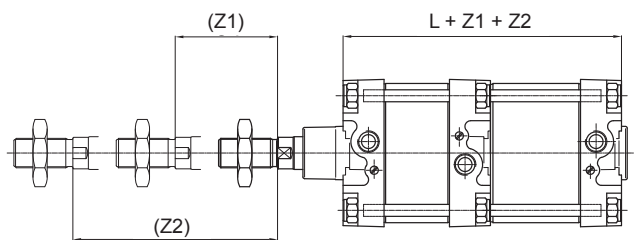

Z = Stroke	
Ø	L
160	340
200	350

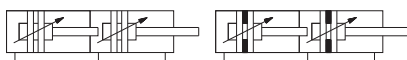

Two-position cylinders with two independent piston-rods which allow to realize a double positioning in which the thrust forces are the same as those of an ISO cylinder of the same bore size.

For all other dimensions please refer to the standard version on.
For other types of cylinders kindly contact our sales office.

Opposed tandem version

CODIFICATION KEY

K	2	C	1	6	0	0	3	0	0	5	0	M
1	2	3			4			5		6		

1 Series	2 Type	3 Bore (mm)	4 Stroke Z1 (mm)	5 Stroke Z2 (mm)	6 Magnetic
K = Ø 160/200 mm - ISO 15552 Pneumatic Cylinders	1C = Opposed tandem, stainless steel male piston rod 2C = Opposed tandem, chromium-plated steel male piston rod	160 = Ø160 200 = Ø200	Stroke 1 (upon request)	Stroke 2 (upon request)	M = Magnetic version

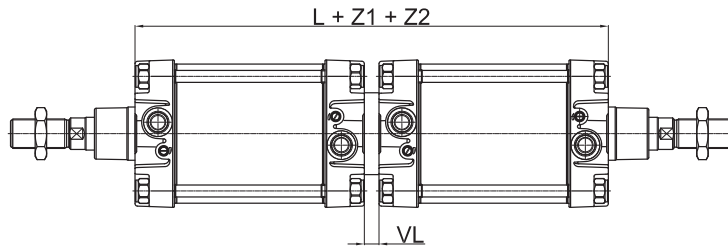

Ø	Z = Stroke	
	L	VL
160	378	18
200	382	22

Type of cylinder characterized by the coupling of two cylinders and whose piston rods move in opposite directions. The values of the thrust force are the same as those of the traditional cylinders.

With common piston rod tandem version (upon request)

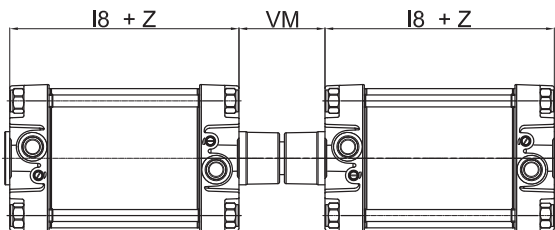

Ø	Z = Stroke			
	L	I8	VM	
160	378	180	±1,1	152
200	382	180	±1,1	167

Two coupled cylinders with common piston rod
 The values of the thrust force are the same as those of the traditional cylinders.
 For all other dimensions please refer to the standard version.
 For other types of cylinders kindly contact our sales office.

Female rear hinge (ISO MP2) with pin

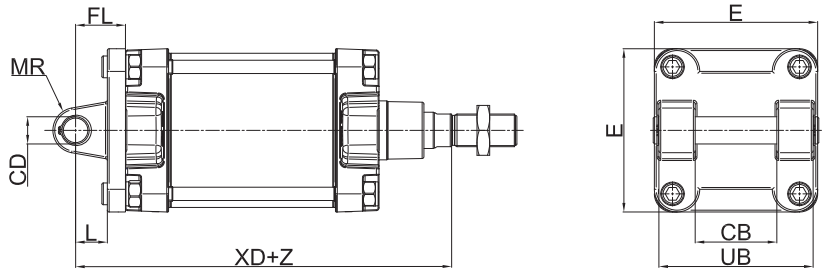
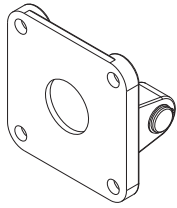

Material: Aluminium

Z = Stroke

Ø	CB	CD	E	FL	L	MR	UB	XD		Mass g	Part no.
	H14	H9		± 0,2	min.	max		h14			
160	90	30	180	55	35	31	170	315	±2	3460	KF-10160A
200	90	30	220	60	35	31	170	335	±2	4610	KF-10200A

Narrow female hinge with pin (DIN648K)

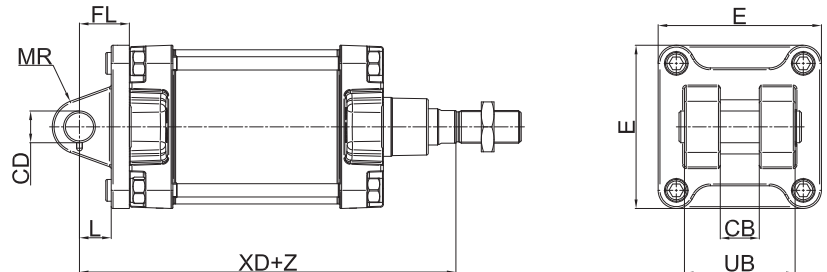
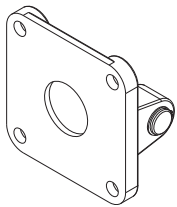

Material: Aluminium

Z = Stroke

Ø	CB	CD	E	FL	L	MR	UB	XD		Mass g	Part no.
	H14	H9		± 0,2	min.	max		h14			
160	43	35	180	55	35	30	122	315	± 2	3002	KF-10160AS
200	43	35	220	60	35	30	122	335	± 2	4372	KF-10200AS

Pin for female hinge

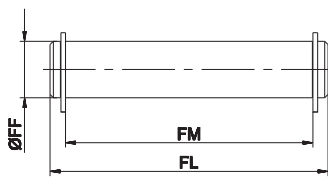

Including 2 circlips

Material: Zinc-plated steel

Cylinder Ø	FF	FL	FM	Mass g	Part no.
	f8				
160 - 200	30	205	171	978	KF-18160*

* = Pin for part no. KF-10...

Pin for narrow female hinge

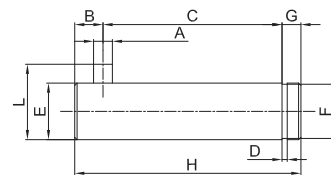

Including circlip

Material: Zinc-plated steel

Ø	A	C	D	E	F	G	H	L	B	g	Part no.
	H12	^{+0,5} / _{+0,3}	h13	f7	h11		⁰ / _{-0,5}				
160	6	119	1,6	35	33	7	135	41	9	26	KF-18160S
200	6	119	1,6	35	33	7	135	41	9	42	KF-18040S

Rear male hinge (ISO MP4)

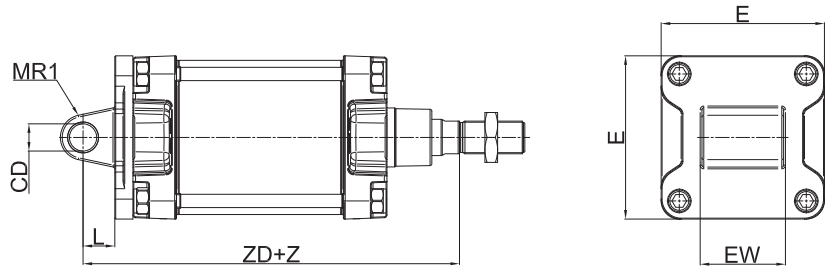
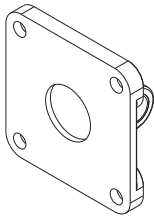

Material: Aluminium

Z = Stroke

Cylinder Ø	CD	E	EW	L	MR	XD	Mass	Part no.
	H9			min.			g	
160	30	180	90	35	31	315	1846	KF-11160
200	30	220	90	35	31	335	2950	KF-11200

* = Non-standard dimension

Articulated rear male hinge (ISO MP6)

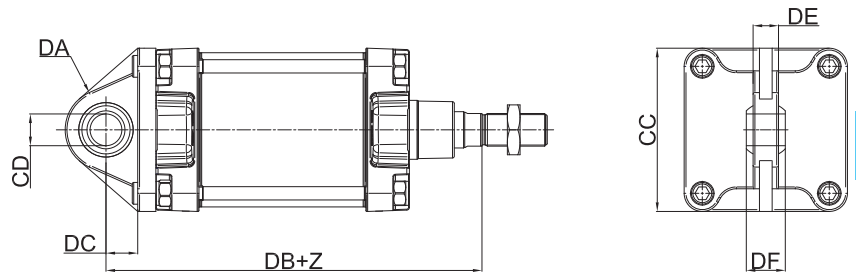
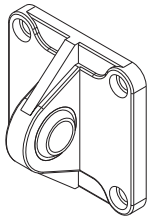

Material: Aluminium

Z = Stroke

Cylinder Ø	CC	CD	DA	DB	DC	DE	DF	Mass	Part no.
		H7						g	
160	180	35	45	315	35	28	43	2420	KF-11160S
200	220	35	48	335	35	28	43	3840	KF-11200S

* = Non-standard dimension

Front/rear flange (ISO MF1-MF2)

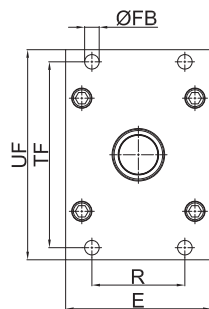
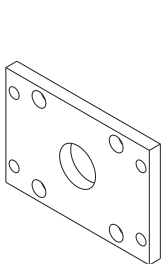

> Rear assembly

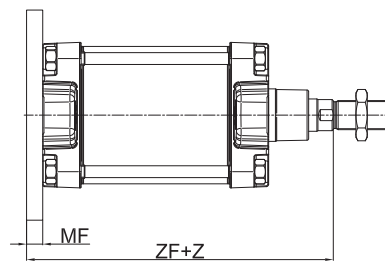

> Front assembly

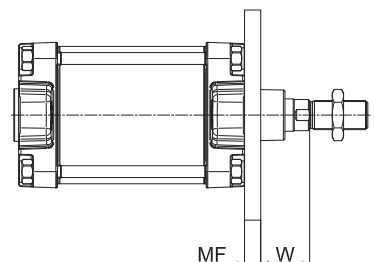

Material: Zinc-plated steel

Z = Stroke

Cylinder Ø	E	FB	MF	R	TF	UF	W	ZF	Mass	Part no.		
		H13	± 0,2	JS14	JS14	max			g			
160	180	18	20	115	230	260	60	±2,5	280	±2	7000	KF-12160
200	220	22	25	135	270	300	70	±2,5	300	±2	12400	KF-12200

Angle bracket (ISO MS1)

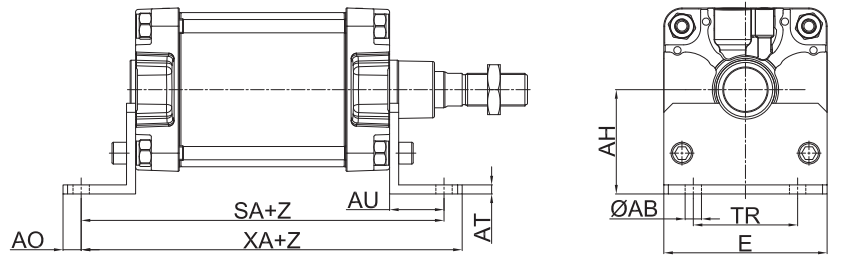
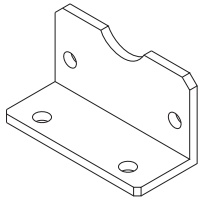

Material: Zinc-plated steel

Cylinder Ø	ØAB	AH	AO	AT	AU	E	SA	TR	XA	Mass	Part no.
	H13	JS15			±0,2			JS14		g	
160	18	115	20	10	60	180	300	±2	115	2530	KF-13160
200	22	135	30	10	70	220	320	±2	135	4300	KF-13200

Z = Stroke

* = Non-standard dimension

ISO intermediate hinge (ISO MT4)

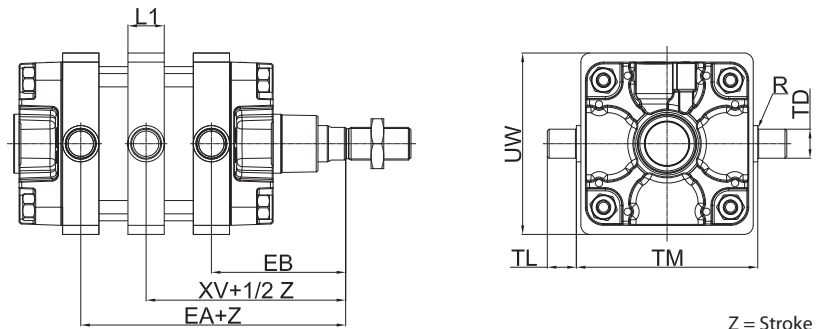
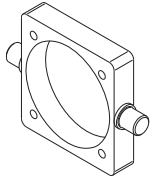

Material: Zinc-plated steel

Cylinder Ø	EA	EB	TD	TL	TM	UW	L1	XV	R	Mass	Part no.
	Max	Max								g	
160	240	148	32	32	200	200	40	218	±2,5	4300	KF-14160
200	255	163	32	32	250	250	40	233	±2,5	7450	KF-14200

Z = Stroke

Front/rear hinge with floating pin

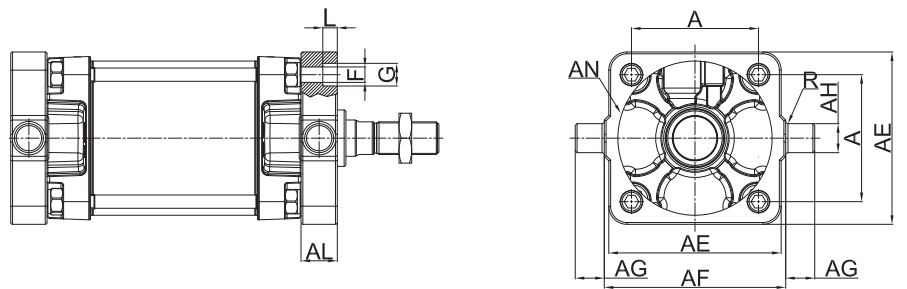
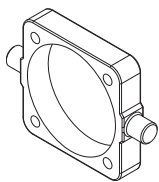

Material: Zinc-plated steel

Cylinder Ø	AE	AL	AH	AG	AF	AN	A	F	G	L	R	Mass	Part no.
	Max	Max	e9	h14	h14	+0,2/0	±0,2	H13	H13	+0,5/0	0/-0,3	g	
160	190	40	32	32	200	170	140	17	25	16	2,5	4150	KF-14160AP
200	240	40	32	32	250	211	175	17	25	16	2,5	7350	KF-14200AP

1
CYLINDERS

Counter hinge 90° (CETOP RP107P)

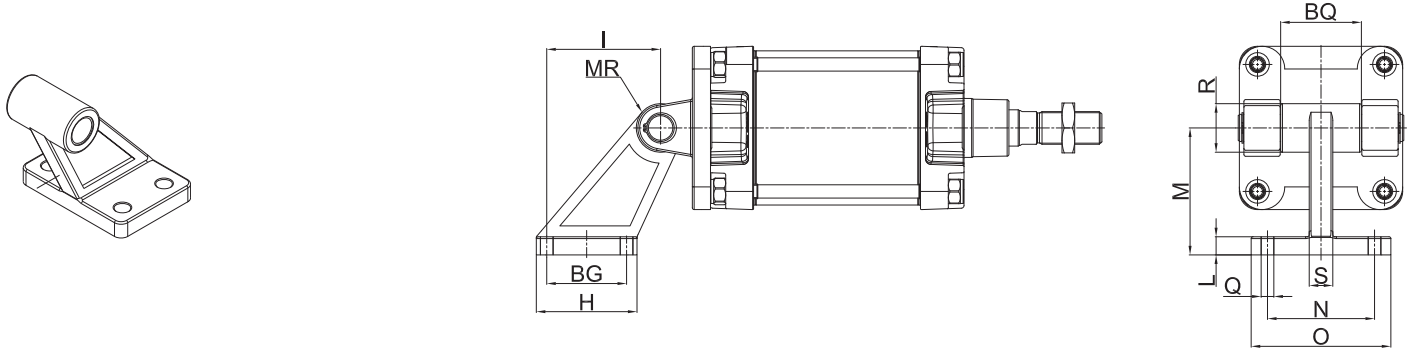

Material: Aluminium

Cylinder Ø	Q	BG	H	I	L	M	O	N	S	R	BQ	G	Mass	Part no.
	H13	JS14	Max	JS14		JS15	Max	JS14	Max	Max	-0,5/-1,2	H9	g	
160	14	88	126	97	25	115	156	118	36	63	90	30	2600	KF-19160CTA
200	18	90	130	105	30	135	162	122	40	63	90	30	3250	KF-19200CTA

* = Non-standard dimension

Hinge support

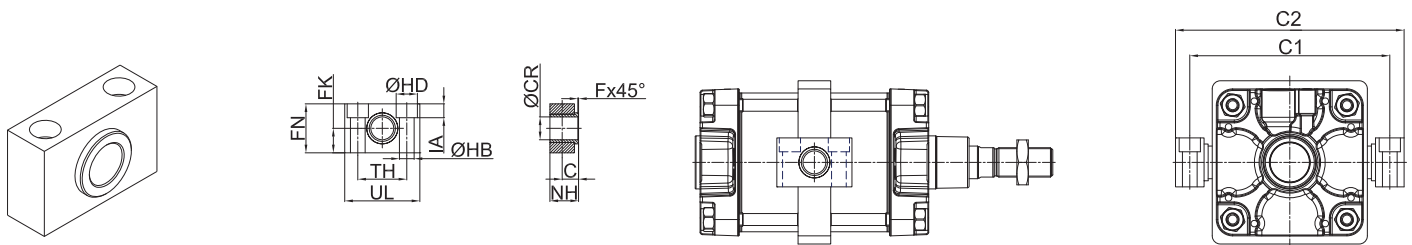

Material: Zinc-plated steel

Cylinder Ø	UL	NH	FN	FK	TH	CR	C	HB	HD	AI	F	C1	C2	Mass	Part no.
														g	
160	92	40	60	30	60	32	22,5	18	26	17	2,5	245	280	850	KF-41160200
200	92	40	60	30	60	32	22,5	18	26	17	2,5	295	330	850	KF-41160200

Articulated self-lubricating fork

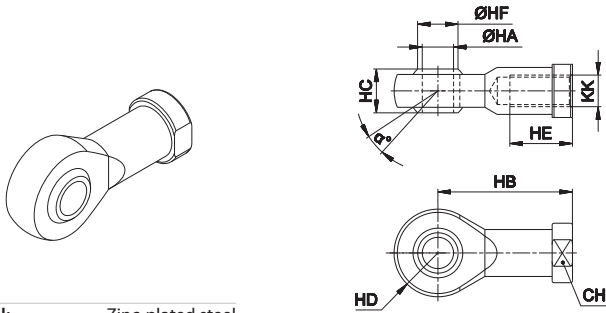

Material: Zinc-plated steel

Cylinder Ø	α°	CH	KK	HA	HB	HC	HD	HE	HF	Mass g	Part no.
160 - 200	16°	50	M36x2	H7	125	43	40 ⁰ _{-0,12}	56	37,7	1595	KF-17160

Female fork with clips

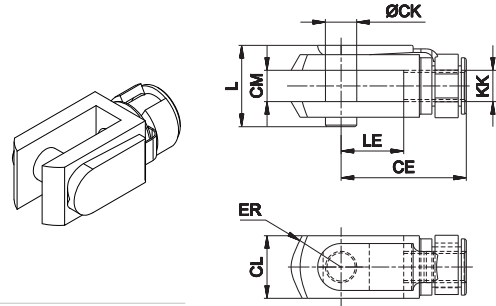

Material: Zinc-plated steel

Cylinder Ø	CE	CK	CL	CM	ER	KK	L	LE	Mass g	Part no.
160 - 200	144	35	70	B12	57	M36x2	81	72	3870	KF-15160

Piston rod locknut (zinc-plated steel)

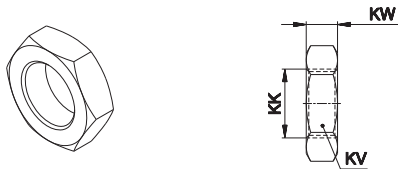

Material: Zinc-plated steel

Cylinder Ø	KK	KV	KW	Mass g	Part no.
160 - 200	M36x2	55	14	170	KF-16160

DH sensor fixing elements

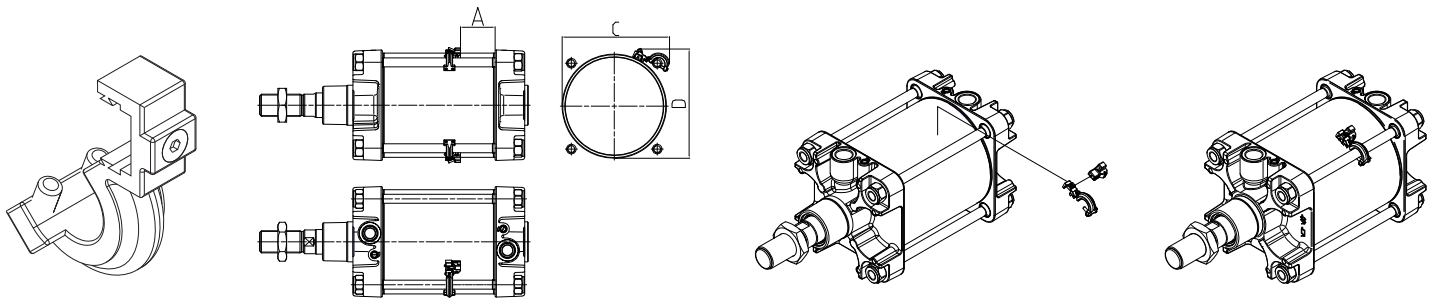

Ø	A - B	C	D	Part no.
160	25 - 27	180	180	DH-K160200
200	24 - 26	200	220	

1
CYLINDERS